

# LT360

**YMT**

*HIGH PERFORMANCE TURNING CENTER*

**FANUC** 0iTD



- ◆ Powerful 20hp Spindle Motor
- ◆ 4,900rpm Maximum Spindle Speed
- ◆ 8" or 10" Hydraulic Chucking System
- ◆ Rigid 30° Slant Bed Casting
- ◆ Precision Hardened & Ground Ballscrews
- ◆ Linear Guide Way Construction
- ◆ Heat Exchanger for Electrical Cabinet
- ◆ Automatic Lubrication System
- ◆ Fluorescent Work Lamp
- ◆ 42 gal Capacity Coolant Tank
- ◆ Set of Hard & Soft Jaws
- ◆ MT-4 Live Center, Safety Door
- ◆ Fast 12 Position Servo Turret
- ◆ None Stop Bi-Directional Tool Indexing
- ◆ Tailstock with Programmable Quill
- ◆ Chip Conveyor & Chip Bucket
- ◆ AC Digital Servo & Spindle Drives
- ◆ 8.4" Color LCD Monitor
- ◆ Dynamic Graphic Display
- ◆ Micro-B & High Speed Skip Functions
- ◆ 1,024 Meters Memory
- ◆ RS232C Interface & PCMCIA Expansion Slot
- ◆ Swivel Control Panel
- ◆ High Quality & Rigid Meehanite® Casting

## Specifications

## LT360

### ▼ MACHINE CAPACITY

Swing Over Bed	ø600mm (23.6")
Swing Over Carriage	ø400mm (15.7")
Max. Turning Length	ø470mm (18.5")
Max. Turning Diameter	ø360mm (14.2")

### ▼ TRAVEL

Z / X Travel	500mm (19.7") / 215mm (8.5")
Rapid Feed Rate	Z,X: 36m/min (1,417ipm)
Servo Motor Power	Alpha-12 / Z, X: 2.1kW (2.8hp)

### ▼ SPINDLE

Front Bearing Bore	ø100mm (3.94")
Spindle Bore	ø62mm (2.4")
Bar Capacity	ø51mm (2.0")
Spindle Nose Type	ASA A2-6 / (A2-8 optional)
Spindle Power / Speed	15kW (20hp) / 4,900rpm
Chuck Diameter	ø8" / (ø10" optional)

### ▼ TURRET

Number of Tool	12
Turret Type	Servo-Driven
Tool Size	□ 25 x 25mm (□1" x "1")

### ▼ ACCURACY

Positioning	±0.004mm (±0.00015")
Repeatability	±0.003mm (±0.00011")

### ▼ GENERAL

Power Requirement	220V, 3 Phase, 60Hz
Power Consumption	26kVA
Min. Pneumatic Pressure	85psi
Machine Net Weight (Approx.)	5,790kg. (12,738lb.)

## Accessories

## LT360

	○	×	8"	10"
FANUC 0iTD	●	●	●	●
FANUC 18iTD	○	○	○	○
4,900rpm Spindle	●	×	●	×
3,500rpm Spindle	×	●	×	●
Hydraulic Chuck	●	●	●	●
Collet Chuck and Hydraulic Cylinder	○	○	○	○
Foot Pedal for Chuck	●	●	●	●
Steady Rest	○	○	○	○
O.D. / I.D. Turning Tools	●	●	●	●
Taper Sleeves	●	●	●	●
Boring Bar Bushings & Holders	●	●	●	●
Manual Body Hydraulic Tailstock	●	●	●	●
Programmable Tailstock Body	○	○	○	○
Tailstock Quill	●	●	●	●
Foot Pedal for Tailstock	○	○	○	○
Servo Turret	●	●	●	●
V.D.I. Turret	○	○	○	○
Power Tooling (C-axis)	○	○	○	○
Coolant System	●	●	●	●
Coolant Tank	●	●	●	●
Oil Skimmer	○	○	○	○
Oil Mist Collector	○	○	○	○
Grease Lubrication System	●	●	●	●
Grease Gun	●	●	●	●
Automatic or Manual Tool Setter	○	○	○	○
Bar Feeder & Interface	○	○	○	○
Safety Door	●	●	●	●
Automatic Door	○	○	○	○
Chip Conveyor	●	●	●	●
Work Lamp	●	●	●	●
Tool Kit	●	●	●	●
Leveling Bolts and Pads	●	●	●	●
Operator, Maintenance, Programming Manual	●	●	●	●

Note: The manufacturer reserves the right to modify the design, specifications, mechanisms, etc. to improve the performance of the machine without notice. All the specifications shown above are just for reference.

## DIMENSIONS Unit: mm (inch)

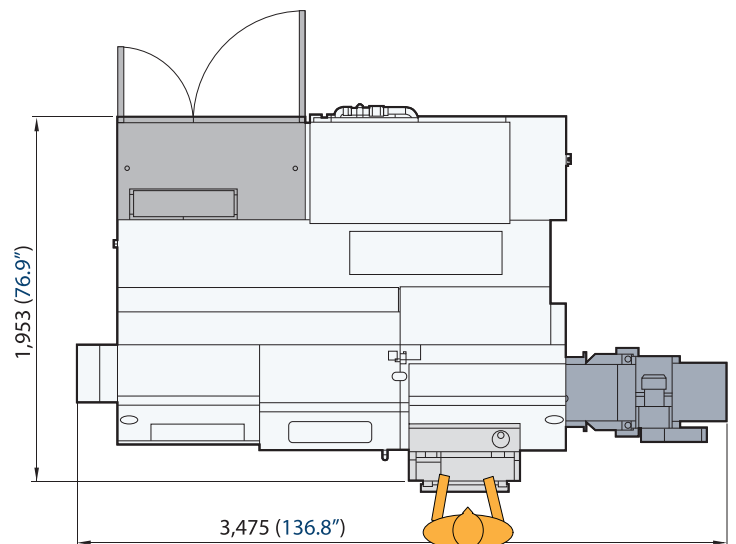
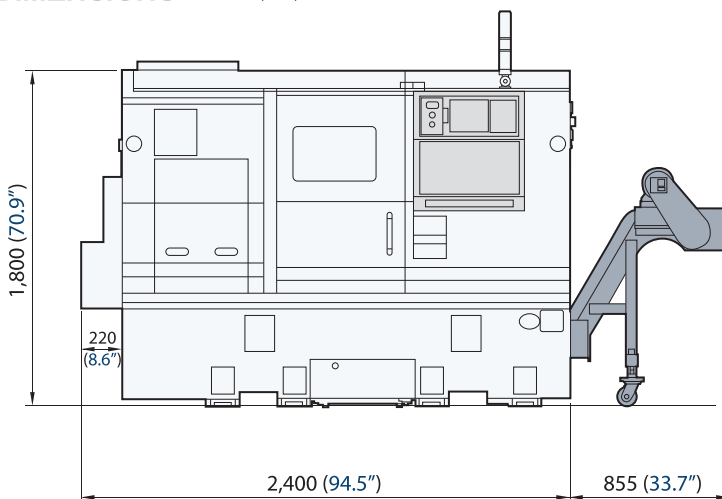

**YMT**  
PRECISION CNC MACHINES

10629 Forest Street  
Santa Fe Springs, CA 90670

www.YMTCNC.com

Tel: 562.645.6118  
Fax: 562.906.6107

DEALER: