

VMC 6535-40

SPECIFICATIONS

General	Imperial	Metric
FLOOR TO TABLE SURFACE	41"	1,041.4 mm
MACHINE WEIGHT	28,400 lbs.	12,882 kg
CONSTRUCTION	Cast Iron on Box Way X/Y/Z	
Table		
TABLE SIZE	75" x 35"	1,905 mm x 889 mm
T-SLOTS (N.O. x WIDTH x SPAN)	7 x .709" x 4.921"	7 x 18 mm x 125 mm
CUTTING FEED RATE (X/Y/Z)	600 ipm max	15.24 mpm max
RAPID TRAVEL RATE (X/Y)	900 ipm	22.86 mpm
RAPID TRAVEL RATE (Z)	700 ipm	17.78 mpm
MAX. WEIGHT ON TABLE	4,250 lbs. ^c	1,928 kg ^c
BALL SCREW SIZE (X/Y/Z)	2.48" Dia.	63 mm Dia.
LONGITUDINAL (X AXIS)	65"	1,651 mm
LATITUDINAL (Y AXIS)	35"	889 mm
VERTICAL (Z AXIS)	34"	863.6 mm
SPINDLE NOSE TO TABLE	4"-38"	101.6 mm - 965.2 mm
SPINDLE CENTER TO	42"	1,066.8 mm
COLUMNS		
Accuracy		
AXIS POSITIONING**	+/- .0002"	+/- .005 mm
AXIS REPEATABILITY**	+/- .0001"	+/- .0025 mm
Spindle		
POWER TRANSFER	Automatic Mechanical, 2 speed VECTOR Drive	
SPINDLE SPEED	10-10,000 RPM	
SPINDLE ORIENTATION	Electromechanical	
SPINDLE TAPER	No. 40	
Tools		
ATC, NUMBER OF TOOLS	24 Tools, 1.9 sec. DATC	
ATC, TOOL SELECTION	Random / Bi-directional	
MAX. TOOL DIAMETER	4"	101.6 mm
(WITHOUT ADJACENT TOOLS)	6"	152.4 mm
MAX. TOOL LENGTH	15"	381 mm
MAX. TOOL WEIGHT	15 lbs.	6.8 kg
Motor		
SPINDLE DRIVE MOTOR	AC VECTOR Drive	
HORSEPOWER	15 HP / 22.5 HP*	18.64 kW / 28 kW*
TORQUE	90 ft.-lbs. / 200 ft.-lbs. *	199 N-m / 504 N-m*
OPT. VERY HIGH TORQUE SPINDLE	30 HP* / 270 ft.-lbs.*	22.4 kW* / 366 N-m *
AXIS DRIVE MOTOR (X/Y/Z)	AC, 5,000 lb s.* thru st	AC, 11,023 kg* thru st
Miscellaneous		
AIR PRESSURE REQUIREMENT	80-100 PSI, 20 SCFM (Mom entary)	5.5-6.9 Bar, .57m ³ /min (Mom entary)
POWER REQUIREMENT (3- Phase)	63 A @ 230 V AC	
OPTIONAL SINGLE PHASE	Not Available	
COOL POWER	Spindle, (X/Y/Z) Ballscrews	

Options

- 62-Position DATC (CAT or BT)
- Chain Hoist Access
- Spindle Options
 - 10,000 RPM Very High Torque (240V)
 - 10,000 RPM Air/Oil Spindle
 - 15,000 RPM Air/Oil Spindle
- Coolant thru Spindle (250 psi)
- Rigid Tapping
- Coolant Wash Down
- Flat Sheet Metal Cover
- Additional Work Light
- Remote Manual Pulse Generator
- 32MP Control
 - Ability to Network
 - High Capacity Hard Drive
 - Shop Floor Programming
- Expanded Memory Levels
 - 422K RAM Memory
 - 4 MB RAM Memory
 - 8 MB RAM Memory
 - 16 MB RAM Memory
- 3.5" Floppy Disk Drive
- Heidenhain Glass Scales
- Renishaw Touch Probes
 - TS-27R Tool Setter Probe
 - MP-11 Probe System
 - MP-12 Probe System
- Rotary Products
 - VH-5C
 - VH-165 mm
 - VH-175 mm
 - VH-225 mm
 - VH-275 mm
 - TR-165 mm (5-Axis)
 - V-300 mm
 - V-400 mm
 - Rotary Accessories
- Tooling Packages
 - (11) Tool Starter Package
 - (20) Tool Premium Package
 - Tooling Certificates

VMC 6535-40 TABLE DIMENSIONS

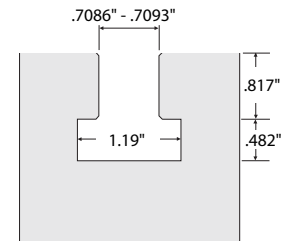
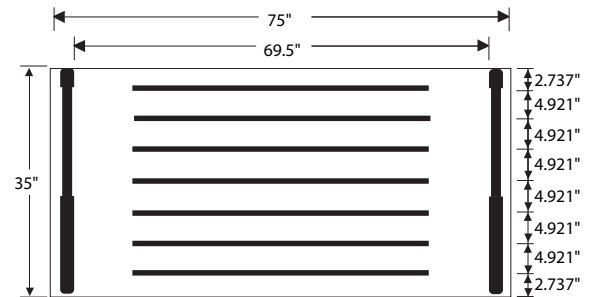

T-SLOT

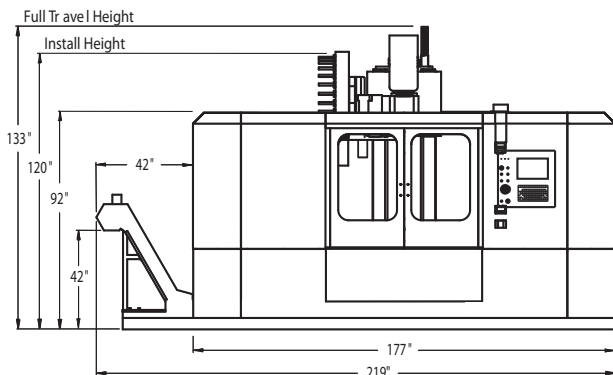

Front View

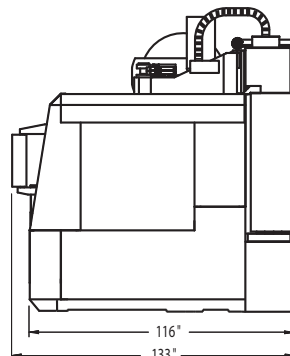

Side View

^c Evenly Distributed Weight

* Peak

** All accuracies are quoted at 68°F.

Fadal reserves the right to change standard and optional machine accessories.

Continuous equivalent A-weighted sound pressure at workstation is 77 db(A) or less during normal cutting operations.